



ESSEX

ESSEX[®]
INTERNATIONAL, INC.

*Electrical Products
for the world's growth industries*

**basic products
and markets
directory**

Table of contents

	PAGE
Essex Divisions and Product Marketing Locations...	2
Basic Products	6
Automotive Products	6
Communications Products—Components	7
Construction Products	9
Consumer Products	10
Control Devices—Components	11
Electric Utility Products	13
Electrical—Electronic Products—Components..	13
Electrical Insulation Materials	16
General Industrial Products—Services.....	18
Plastic Products	19
Basic Products List	20
Sales Offices & Warehouses	23

GENERAL OFFICES
ESSEX INTERNATIONAL, INC.
1601 Wall Street, Fort Wayne, Indiana 46804 (219) 743-0311

ESSEX



Essex was originally organized in 1900 and began the production of basic electrical wires and devices. The company has since grown to become recognized as a primary manufacturer of a broad range of market oriented products required by all the associated businesses making up the "electrical-electronics industry" universe.

Through internal growth programs, in-depth self supply, primary raw material processing operations and special production equipment, the company today produces practically every product type required for the transmission, control, or end-product application of electricity.

The company also manufactures and distributes complete lines of maintenance and repair products for associated aftermarket requirements. In addition Essex likewise produces select products and equipment directed to parallel facets of its long established electrical markets.

The company operates through 10 manufacturing divisions, each producing multi-product lines for maximum market coverage.

ESSEX OPERATIONS

- Communications & CATV Division
- Controls Division
- Electro-Mechanical Division
- Industrial Wire Products Division
- IWI Division
- Magnet Wire Division
- Metal & Plastic Products Division
- Power Conductor Division
- Wire Assembly Division
- Wire & Cable Division
- Transport Motor Express

Essex Divisions and Product Marketing Locations

ESSEX COMMUNICATIONS & CATV DIVISION

800 E. Garfield Ave., Decatur, Ill. 62526 (217) 429-2531

Manufactures and markets all types of overhead and direct burial communications wire and cable, telephone cable carrier systems and community antenna television (CATV) equipment.

ESSEX CONTROLS DIVISION

131 Godfrey St., Logansport, Ind. 46947 (219) 753-7521

Manufactures and markets magnetic, gas, temperature and related control devices and systems, small transformers; markets transformers and controls through authorized electronic distributors.

electro-mechanical controls

ESSEX/RBM Controls
131 Godfrey St., Logansport, Ind. 46947 (219) 753-7521

bimetallic temperature controls

ESSEX/Stemco Controls
P. O. Box 1007, Mansfield, Ohio 44903 (419) 884-1311

capillary actuated temperature controls

ESSEX/Temperature Control Products
4200 Miami St., St. Louis, Mo. 63116 (314) 776-7667

gas controls

ESSEX/Gas Controls
West Township Road, Auburn, Ind. 46706 (219) 925-2461

gas manifolds

ESSEX/GASCO Products
Columbia Highway, P. O. Box 625, Franklin, Tenn. 37064 (615) 794-8451

distributor marketing (transformers, wire products)

ESSEX/Stancor Products
3501 W. Addison St., Chicago, Ill. 60618 (312) 463-7400

distributor marketing (electrical, electronic control devices)

ESSEX/RBM Control Products
131 Godfrey St., Logansport, Ind. 46947 (219) 753-7521

gas valves and accessories

ESSEX/Roberts Brass Products
Grissom Ave., Mitchell, Ind. 47446 (812) 849-3100

ESSEX ELECTRO-MECHANICAL DIVISION

6233 Concord Ave., Detroit, Mich. 48211 (313) 921-5600

Manufactures electrical switching and control devices and components required by manufacturers of vehicular and marine equipment for ignition, operation, convenience and safety. Markets electrical wires, cables, switches, ignition devices and components, starter drives and water pumps to automotive aftermarket.



automotive aftermarket products

ESSEX/Automotive Parts
6233 Concord Ave., Detroit, Mich. 48211 (313) 921-5600
Ext. 297

automotive water pumps—aftermarket

ESSEX/Warner Machine Products
P.O. Box 2423, Muncie, Ind. 47302 (317) 288-4464

ESSEX INDUSTRIAL WIRE PRODUCTS DIVISION

445 Park Ave., Sycamore, Ill. 60178 (815) 895-4501

Manufactures and markets electrical wiring systems; electronic, high temperature and coaxial wires and cables; cord sets; power, lead, hook-up and special wires and cables for appliance, OEM, refrigeration, CATV and special markets; also produces terminals, moldings, terminating and molding machines.

electrical wires, cord sets

ESSEX/Industrial Wires & Cables
445 Park Ave., Sycamore, Ill. 60178 (815) 895-4501

electronic, high temperature, coaxial wires & cables

ESSEX/Electronic Wires & Cables
6235 S. Harlem Ave., Chicago, Ill. 60638 (312) 586-3000

electrical terminals, moldings, equipment

ESSEX/Terminals
3501 W. Addison St., Chicago, Ill. 60618 (312) 463-7400

electrical appliance wiring systems

ESSEX/Electrical Wire Assemblies
100 Tudor Rd., Berrien Springs, Mich. 49103 (616) 471-7721

ESSEX IWI DIVISION

1510 Wall St., Fort Wayne, Ind. 46804 (219) 742-7441

Distributes electrical insulation and wire products, components, fabricated non-metallic and mica parts, shop equipment, controls, capacitors, small motors and related electrical products. Manufactures and distributes natural and built-up mica products, tubing and sleeving, and fabricated electrical insulating parts.

insulation materials, wire, equipment for OEM and motor repair/maintenance

ESSEX/IWI
1510 Wall St., Fort Wayne, Ind. 46804 (219) 742-7441

refrigeration, air conditioning, heating replacement products

ESSEX/IWI-Steveco
1510 Wall St., Fort Wayne, Ind. 46804 (219) 742-7441

fabricated parts/electrical insulation materials

ESSEX/IWI-Cortland
4545 Cortland St., Chicago, Ill. 60639 (312) 227-1500

natural mica products

ESSEX/IWI-Huse Liberty
247 Lynnfield St., Peabody, Mass. 01960 (617) 531-7100

Essex Divisions and Product Marketing Locations (continued)

ESSEX IWI DIVISION (continued)

built-up mica products

ESSEX/IWI-Macallen
Bay Rd., Newmarket, N.H. 03857 (603) 659-5555

tubing and sleeving

ESSEX/IWI-Suflex
33-40 57th St., Woodside, N.Y. 11377 (212) 639-5530

ESSEX MAGNET WIRE DIVISION

1601 Wall St., Fort Wayne, Ind. 46804 (219) 743-0311

Manufactures and markets complete lines of copper and aluminum magnet wires; precious metal-plated conductors; diamond dies for wire drawing; fine and ultra-fine precision stainless steel and stainless alloy wire; organo-metallic compounds, resins, emulsions and suspensions. Designs and manufactures custom production machinery and special industrial processing equipment. Engineers, manufactures and markets automatic stator winding equipment and related systems.

copper and aluminum magnet wire

ESSEX/Magnet Wire
1601 Wall St., Ft. Wayne, Ind. 46804 (219) 743-0311

custom production machinery

ESSEX/Custom Machinery
211 N. Columbus St., Lancaster, Ohio 43103 (614) 653-4216

stator winding equipment

ESSEX/Fort Wayne Tool & Die
3405 Engle Rd., Fort Wayne, Ind. 46809 (219) 747-0540

precision stainless alloy wire

ESSEX/Fort Wayne Metals
3211 MacArthur Dr., Fort Wayne, Ind. 46809 (219) 747-4154

organo-metallic compounds, resins, emulsions, suspensions

ESSEX/Copolymer Products
2800 North Main St., Rockford, Ill. 61101

ESSEX METAL & PLASTIC PRODUCTS DIVISION

303 N. Jackson, Andrews, Ind. 46702 (219) 786-3371

Manufactures and markets industrial fittings, high pressure hose lines; aluminum extrusions; rigid and flexible plastic extrusions, plastic vacuum formed and injection molded parts. Designs, manufactures and markets point-of-purchase displays and complete lines of indoor and outdoor illuminated plastic signs.



metal fittings, plastic products

ESSEX/Fittings-Plastics
303 N. Jackson, Andrews, Ind. 46702 (219) 786-3371

aluminum extrusions

ESSEX/Aluminum
835 Spring St., Jeffersonville, Ind. 47130 (812) 282-4341

illuminated signs

ESSEX/NPI (Neon Products, Inc.)
Neon Ave., Lima, Ohio 45802 (419) 223-9045

ESSEX POWER CONDUCTOR DIVISION

2601 S. Adams St., Marion, Ind. 46953 (317) 664-6211

Manufactures and markets copper and aluminum overhead and underground high voltage wires and cables for utilities, power companies, municipalities and general industrial applications.

ESSEX WIRE & CABLE DIVISION

1508 Wall St., Fort Wayne, Ind. 46804 (219) 743-0311

Manufactures and markets full lines of aluminum and copper building wires and cables for construction, mining, mobile home, service and general industries through electrical wholesalers.

ESSEX WIRE ASSEMBLY DIVISION

6233 Concord Ave., Detroit, Mich. 48211 (313) 921-5600

Designs, engineers, manufactures, and markets complete electrical wiring and control systems, including the associated component devices required by the automotive, truck, bus, farm equipment, off the road, and marine industries.

ESSEX/CASCO

P. O. Box 547, Belton, S.C. 29627 (803) 338-7764

Manufactures and markets automatic electric blankets and heating pads, plus associated lines of consumer therapeutic and health products through drug, pharmacy and housewares outlets.

TRANSPORT MOTOR EXPRESS, INC. (TMX)

P. O. Box 958, Meyer Rd., Fort Wayne, Ind. 46801
(219) 743-9711

Major commercial truck line serving midwestern states through network of freight terminals.

Basic Products

Automotive Products

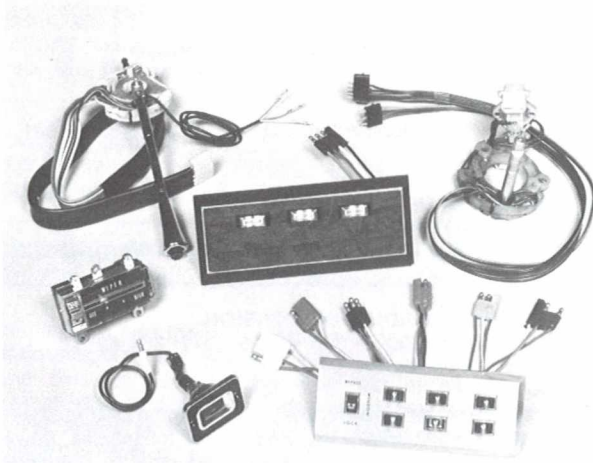

Automotive Electro-Mechanical Devices and Components

Relays, voltage regulators, starter solenoids, flashers, indicators and dimmers; complete line of switches for headlamps, courtesy lights, turn signals, hazard warnings, speed controls, window lifts, windshield wipers-washers, ignition, neutral safety, etc. ESSEX ELECTRO-MECHANICAL DIVISION (pg. 2)

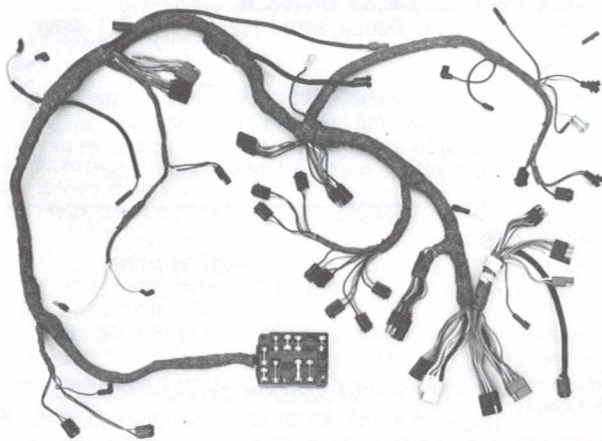

Automotive Wiring and Control Systems

Complete wire assemblies for all electrical, electro-mechanical functions including interior and exterior lights, courtesy lamps, transmission indicators, ignition and engine electrical systems, and other automotive safety, convenience and operational requirements. ESSEX WIRE ASSEMBLY DIVISION (pg. 5)



Automotive Aftermarket Products

Battery cable sets, terminals, carrier straps, hold downs, post cleaners and jumper cable sets; coils, brackets, and resistors; distributor caps; ignition wire; starter solenoids, starter drives, and repair kits; terminals and terminal kits; voltage regulators and fuses; booster clamps-clips; brushes; condensers; contact sets; cutouts; dashpots; drop lights; extension cord (spooled, readymade); flasher controls; horn buttons; lamp assemblies; lock cylinders and keys; loom; magneto parts; PVC valves; relays; spark plug and distributor boots; switches; temperature sending units; trailer connectors; transmission modulators; vacuum chambers; voltage reducers; warning devices; water pumps; wire and cable. ESSEX/Automotive Parts (pg. 3)

Communication Products—Components

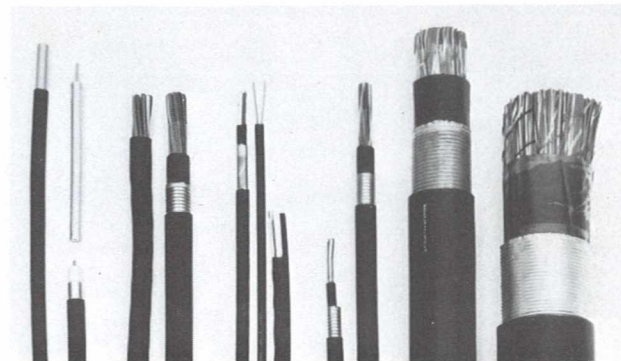

Communication Wire & Cable

Aerial and buried distribution wire, inside-outside station wire, aerial drop wire, aerial figure-8 cable, aerial and duct cable, direct burial cable, low capacitance cable, inside wiring cable, filled cable, steel shielded cable, high pair count cables, special constructions. ESSEX COMMUNICATIONS & CATV DIVISION (pg. 2)

Coaxial cable, sub-miniature coaxial cable, triaxial cable, audio cable, antenna wire, twin lead transmission lines. ESSEX/Electronic Wires & Cables (pg. 3)

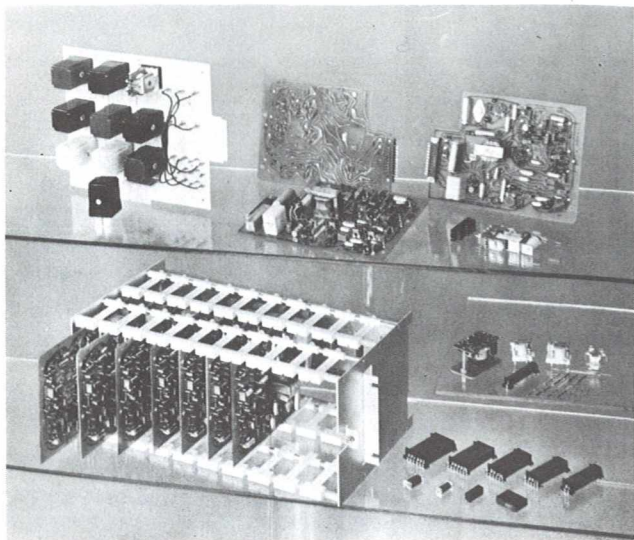

Communication Cable Carrier Systems

Electronic cable carrier systems used by telephone companies featuring standard subscriber telephones with special station terminating electronics and plug-in central office electronic terminals. ESSEX COMMUNICATIONS & CATV DIVISION (pg. 2)

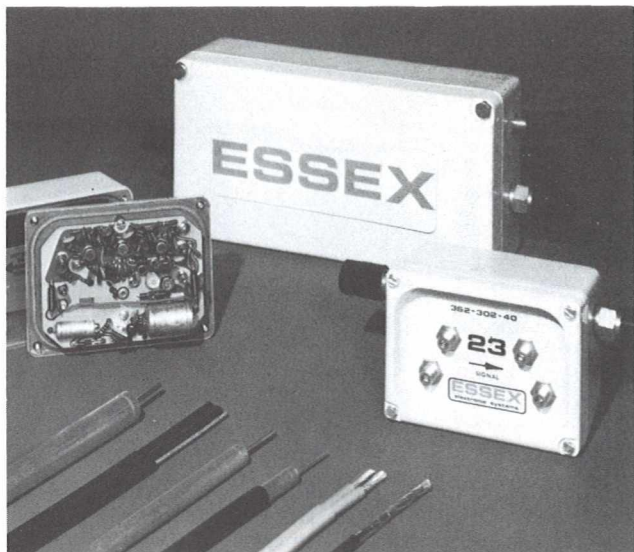

CATV Equipment and Cables

Amplifiers, automatic program switchers, CATV wire and cable, directional couplers, power inserters, power supplies, line splitters. ESSEX COMMUNICATIONS & CATV DIVISION (pg. 2)



Construction Products

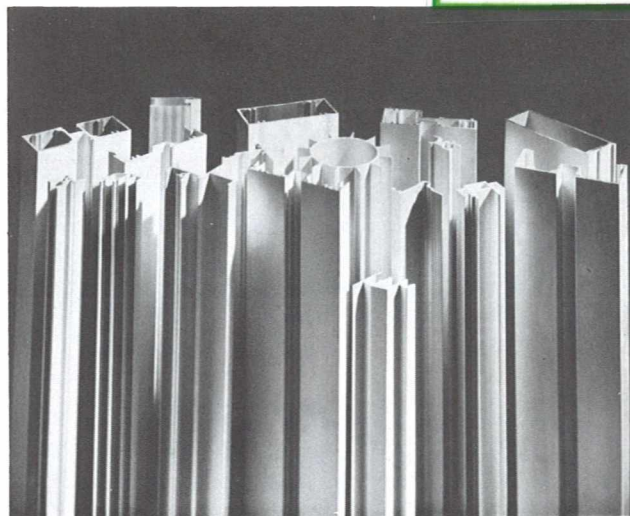

Aluminum Extrusions

Storm windows and doors; prime windows for residential and commercial use; aluminum weather stripping channels; store front extrusions and components; decorative and structural trim; miscellaneous aluminum building products; sports equipment components. ESSEX/Aluminum (pg. 5)



Building Wires & Cables

Solid and stranded copper and aluminum conductors; non-metallic sheathed cables; fixture wires; line wires; armored wires and cables; service entrance cables; self-supporting service drop cables. ESSEX WIRE & CABLE DIVISION (pg. 5)

Basic Products (continued)

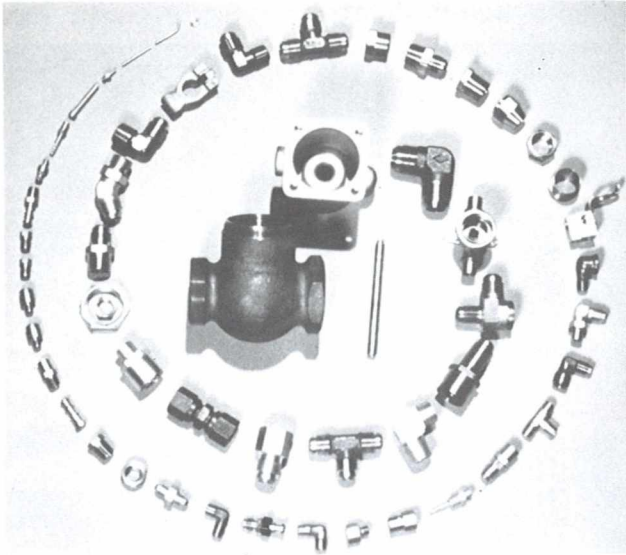

Fittings

Brass, steel and bronze alloy fittings; flared, flareless, inverted flare, precision grip, compression and threaded sleeve fittings; high pressure fittings. ESSEX/Fittings-Plastics (pg. 5)

Consumer Products



Automatic electric blankets and heating pads; therapeutic health appliances; heat bonnets; sinus masks; heat masks; heat bandages; neck and throat heat pads; facial saunas; thermal massagers; oral hygiene appliances; illuminated make-up mirrors. ESSEX/Casco (pg. 5)



Control Devices—Components

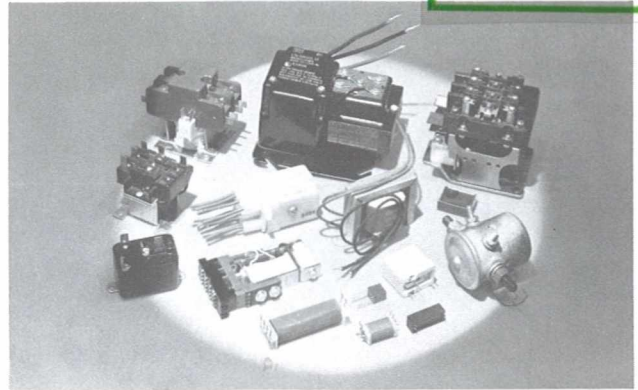

Control Systems & Relays

Controls and control systems for appliances, business machines and computers; general purpose and current type relays; hermetically sealed, low voltage DC, miniature sensitive, motor starting, plug-in, and potential type relays and contactors; printed circuits, reed, refrigeration, resistance sensitive, time delay and shunt type relays and contactors; air conditioning, automatic defrost, heating, and vending machine controls; thermal and hermetically sealed controls and control systems. ESSEX CONTROLS DIVISION (pg. 2)

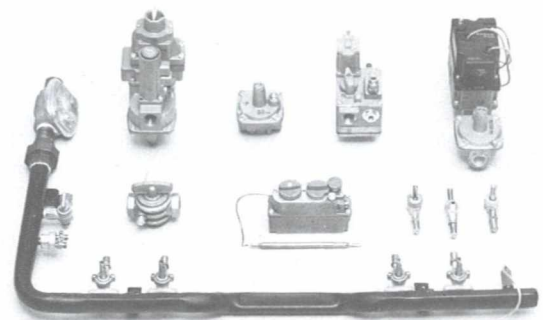

Gas Controls & Manifolds

Gas controls: boiler, central furnace, duct furnace, electric ignition, flame failure, gas fired air conditioning, gas ignition, infra-red heater, room heater, unit heater and wall furnace. Gas valves: automatic, bimetal actuated, combination, electromagnetic actuated, manual and pilot; gas pressure regulators. ESSEX / Gas Controls (pg. 2)

Manifolds: furnace and gas appliance. ESSEX/GASCO Products (pg. 2)

Top burner valves, orifices, connectors, water gauges. ESSEX/Roberts Brass Products (pg. 2)

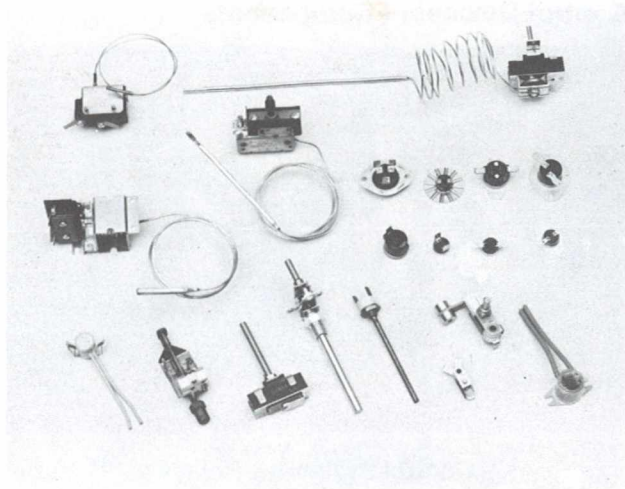

Temperature Controls

Automatic pilots; gas capillary, flame and thermal controls; glow coil igniters. Thermostats: adjustable strip, electric, disc type, heliarc welded, hermetically sealed, manual reset, potted, semi-enclosed, and solder sealed. ESSEX/Stemco Controls (pg. 2) Hydraulic actuated capillary thermostats. ESSEX/Temperature Control Products (pg. 2)

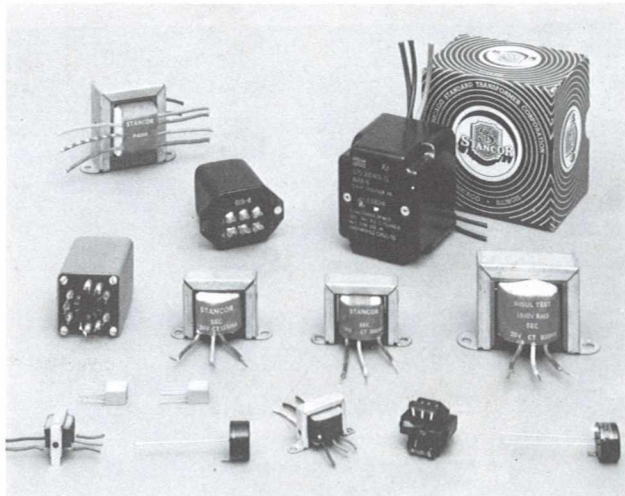

Transformers

Transformers: audio, control, driver, electric, electronic, filament, flyback, input, interstage, isolation, line matching, matching, microphone, miniature, sub-miniature, modulation, output, photo flash, plate, power, yoke, filter choke, swinging choke, TV/radio replacement. ESSEX/Stancor Products (pg. 2)



Electric Utility Products

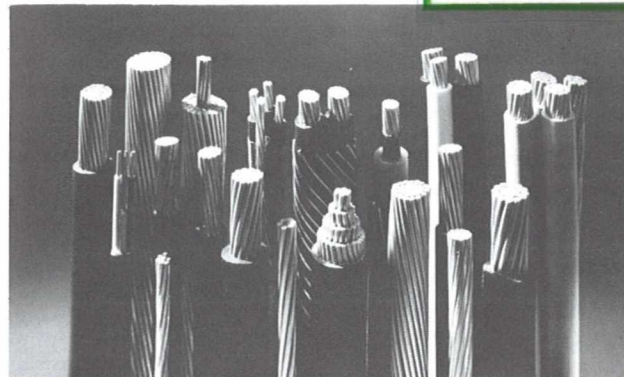

Electrical Power Cables

Copper and aluminum, solid and stranded conductors, primary and secondary overhead and underground, high voltage wires and cables; service entrance drop cables; spacer cable; mining cable; welding cable; control cable and special cables such as cable-in-duct and interlocked armored cable; standard and customized insulations including plastic, rubber, butyl, neoprene, polyethylene and cross-linked polyethylene. ESSEX POWER CONDUCTOR DIVISION (pg. 5)

Electrical—Electronic Products—Components

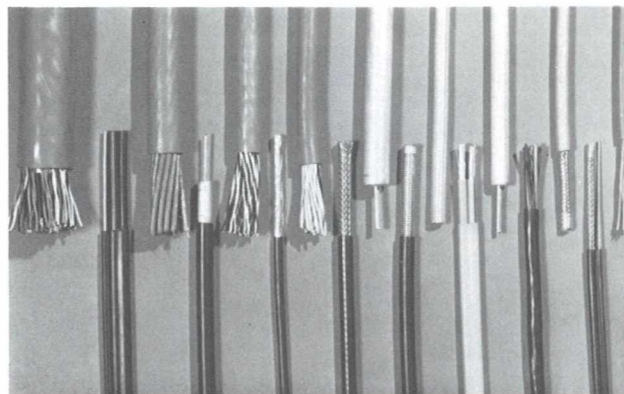

Electronic & Coaxial Wires & Cables

Military hook-up wire: types B, C, D, ET, E, EE, LW, MW and HW. UL hook-up wire: style 1061, 1015, 1016, 1011, 1010, 1008, 1007, 1006, 1426, 1424, 1371, 5073 and 5074. Coaxial cables include RG, RG subminiature, semi-rigid, triaxial, low noise, high voltage, metal jacketed, 100% BC/U and reduced weight cables. Solid or stranded copper conductors, silver or nickel plated. Insulations include mylar, nylon, Teflon, PVC, fiberglass, Kynar, Polysulfane, Lamwrap, etc. ESSEX/Electronic Wires & Cables (pg. 3)

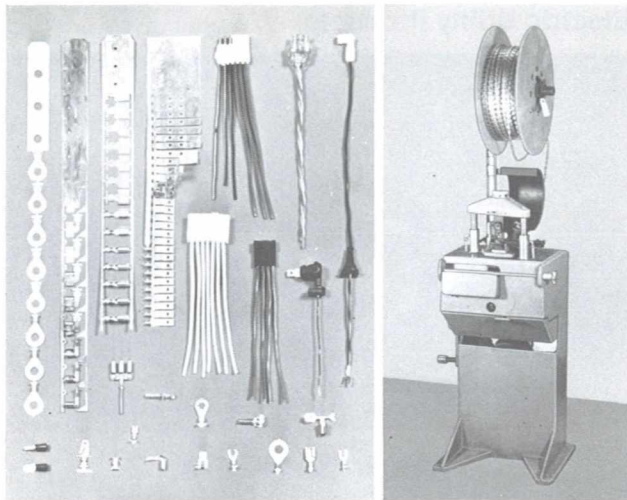

Terminals & Moldings Terminating & Molding Equipment

Electrical and electronic terminals for appliance, automotive and electronic applications; terminals include bullet, headlight, magnet wire piercing, pin, ring, screw, snap-on, spade, spark plug and tab. Terminal applicator presses, crimping dies; moldings, injection molding presses and dies. ESSEX/Terminals (pg. 3)



Magnet Wire

Aluminum, copper and plated conductors; very heavy to ultra-fine sizes; rectangular, square and round wire shapes; insulations include film types, paper, cotton, Kapton, glass and dacron glass over bare wire or in combinations with film insulations. ESSEX/Magnet Wire (pg. 4)

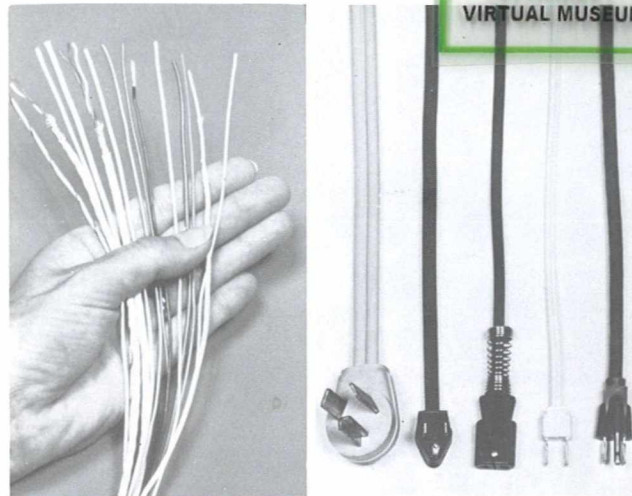

Electrical & Electronic Wires, Cord Sets, Appliance Wire Assemblies

Power, lead, hook-up, and special wiring systems for appliance, OEM, refrigeration and general machine industries; cord sets for air conditioning, appliance, general machine, replacement and portable power applications; electrical wire assemblies for appliance and general industry. ESSEX/Industrial Wires & Cables (pg. 3)

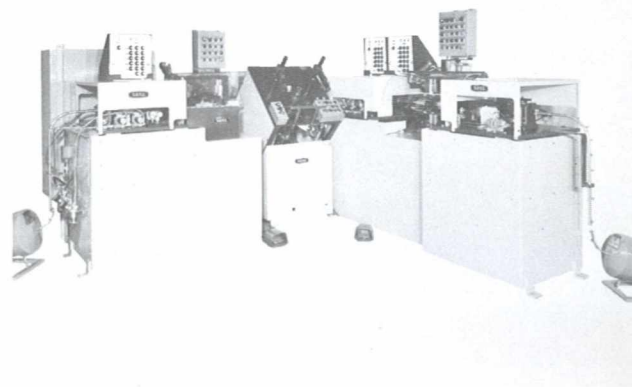

Stator Winding Equipment

All types of stator manufacturing equipment including stator winders, lacers, coil prewinders, coil and wedge inserters, and other related machines required by electric motor and electric coil manufacturers. ESSEX/Fort Wayne Tool & Die (pg. 4)

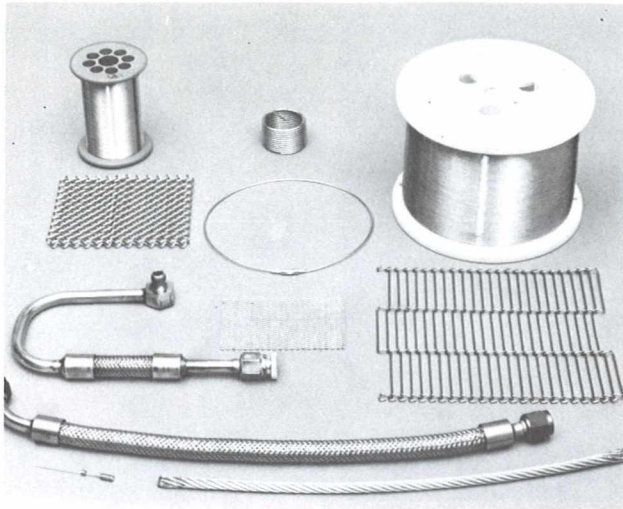

Precision Stainless Alloy Fine Wire

Precision alloy wires from .125 to .0005 and customized smaller sizes for industrial, commercial, military, scientific and medical applications. Drawn braze strand wire; pacemaker cable; weaving wire; suture wire; orthodontic wire; magnetic recording wire. ESSEX/Fort Wayne Metals (pg. 4)

Electrical Insulation Materials

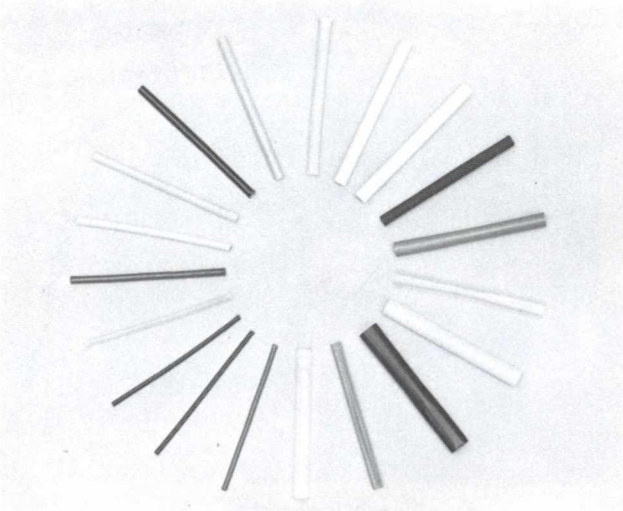

Tubing & Sleeving

Unsupported flexible extruded plastic tubing; cotton rayon varnish saturated; woven glass sleeveings: plain, heat treated and special treatments; special coatings: resin, plastic, rubber, elastomer and others. ESSEX/IWI-Suflex (pg. 4)

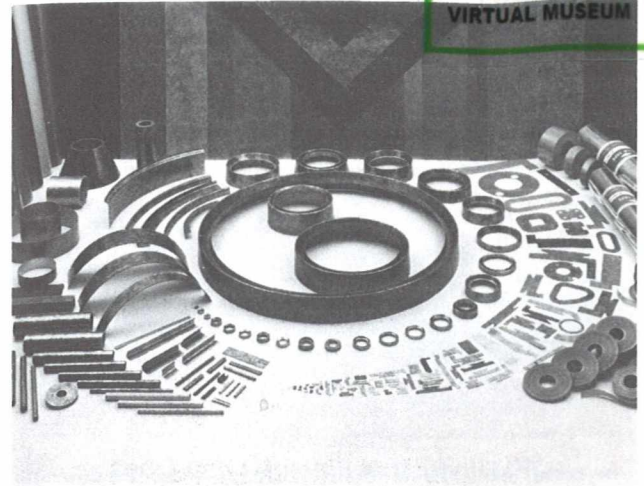

Mica Products

Natural mica products including raw splittings fabricated for vacuum tube grid supports, transistor bases, microwave windows, etc. ESSEX/IWI-Huse Liberty (pg. 3)

Built-up mica products including mica splittings incorporating binders to form rigid plates, molding plates, heater plates; flexible composites in sheets, rolls and tapes; fabricated, molded or formed parts. ESSEX/IWI-Macallen (pg. 4)



Fabricated-Prepackaged Insulations

Precision fabricated electrical insulation parts from various standard non-metallic materials such as paper, fibres, plastic, films, synthetics and others which are punched, drawn, formed, channeled, shaped, drilled, engraved, etc. Off-the-shelf prepackaged products include coil forms, motor slot wedges and hard fibre washers. ESSEX/IWI-Cortland (pg. 3)

General Industrial Products—Services

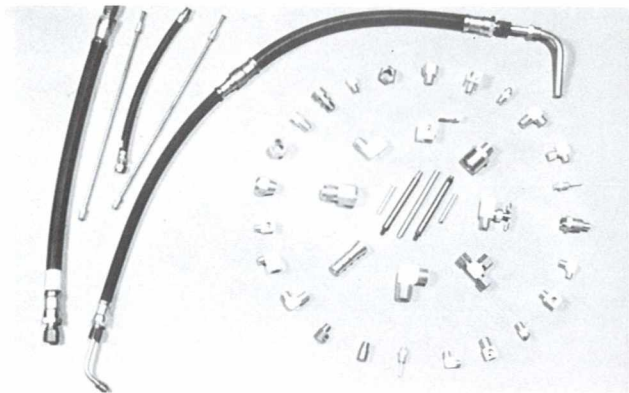

OEM/Industrial Fittings-Hose Lines

Steel and brass fitting types include appliance, air brake, brass, compression, evaporative cooler, flared, flareless, gas range, hose, inverted flare, pipe, POL, refrigeration, space heater, steel and threaded sleeve. Needle and tank instrumentation valves; pipe nipples; low-medium-high pressure hose; hose ends; hose adapters; fuel and oil lines; steel brake lines and power steering hose assemblies. ESSEX/Fittings-Plastics (pg. 5)

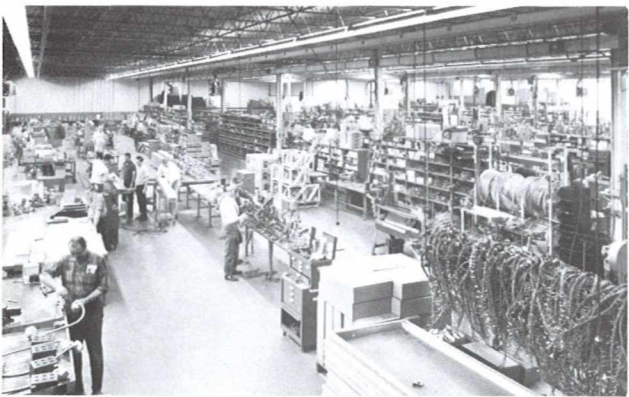

Machinery Building

High speed wire drawing and processing equipment; electrical and electronic production machinery; special laboratory testing equipment; high speed packaging machinery; custom heavy duty machinery; automatic glass-reed-switch assembly and encapsulation equipment; plastic injection molding machines; high speed presses for progressive terminal and crimping dies; automatic circuitry testing equipment; copper bar rolling mills; coiling machines; universal wire take-up machines; stamping presses; Tappi laboratory equipment such as disintegrators, presses with automatic controls, pumps and paper industry sheet making machines. ESSEX/Custom Machinery (pg. 4)



Illuminated Signs

Interior and exterior illuminated plastic dealer signs, merchandising and point-of-purchase displays, high rise signs. Extensive product lines include standard and specially designed signs incorporating clocks, motion, privilege lines and four-color transparencies. ESSEX/NPI (Neon Products, Inc.) (pg. 5)

Plastic Products



General Plastic Product Types

Rigid, flexible, semi-flexible and dual durometer plastic extruded products include cable guy wire guards, waterstop and window moldings, gasketing materials, edging, conduit, tape, tubing and extrusions for the window and door industries. Vacuum formed parts in wide variety of shapes and sizes with special surface patterns, hardware, detail, materials and two-piece molded parts. Injection moldings include thermoplastic parts, spools and housings for general industry; compression, transfer and injection molded thermosetting plastic bobbins, housings, fuse and terminal blocks, knobs, switch and switch-gear components, appliance interior and exterior panels. ESSEX/Fittings-Plastics (pg. 5)

Basic Products List

Aluminum
 extrusions
 fabrications
 magnet wire
 store fronts
 storm windows and doors
 wire and cable
Appliance wire assemblies
Automotive products
 battery cable
 connectors
 harnesses
 ignition components
 ignition switches
 ignition wire
 magnet wire
 primary wire
 starter drives
 switches
 terminals
 warning devices
 water pumps
 wire and cable
Cable (see Wire & Cable)
Cable carrier systems
Capacitors*
CATV systems equipment
 amplifiers
 automatic program
 switchers
 directional couplers
 power inserters
 power supplies
 splitters
Chokes
**Coil & Wedge Inserter
 Equipment**
Commutators*
Commutator brushes*
Commutator saws*
Commutator slotters*
Commutator V-rings
Conduit
Connection blocks
Consumer products
 electric blankets
 heating pads
 heat bonnets
 sinus masks
 heat masks
 heat bandages
 neck and throat heat pads
 propane torch kits*
 portable refrigerators*
 gas camp stoves*
 gas lanterns*
 hand cutting tools*
 leak detector kits*
 facial saunas
 thermal massagers
 oral hygiene appliances
 power drills*
 fire extinguishers*
Control housings
Controls
 automotive
 gas automatic valves
 gas combination valves
 gas main manual valves
 gas pilot valves
 gas top burner valves
 electrical
 electronic
 gas pressure regulators
 hydraulic actuated
 humidistats
 relays
 solenoids
 switches
 system control packages
 thermal
 thermostats
 time delay
 transformers
Cords and cord sets
 air conditioning
 appliance
 extension
 flexible
 general machine
 neoprene insulated
 plastic insulated
 portable power
 replacement
 rubber insulated
Custom machinery
Diamond dies
Drain cocks and valves
Drills, electric*
**Electrical maintenance
 products**
Electronic systems
Extrusions
 aluminum
 plastic (flexible and rigid)
Fan blades*
Fittings
 appliance
 air brake
 brass
 compression
 evaporative cooler
 flared
 flareless
 garden hose
 gas range

*Denotes products distributed but not manufactured by Essex.



hose
 high pressure
 inverted flare
 pipe
 POL
 space heater
 steel
 threaded sleeve
Gas manifolds
Gas pipe, plastic
Gas valves
 automatic
 combination
 manual
 pilot
 top burner
Gasoline Additives
Hose adapters
Hose ends
Hose lines
 auto air brake
 auto power brake
 auto power steering
Injection molding presses
Insulation, electrical
 standard non-metallic
 materials
 pre-packaged insulation
 forms
 custom fabrications
 wire products (magnet,
 others)
Lubricants
 grease, general purpose*
 grease, heat resistant
 oils, heat resistant
 oil additives
Magnet wire
Mica
 natural
 built-up (all forms)
Mica splitting products
Molding machines
Moldings
Motors, replacement*
 air conditioning
 appliance
 heating
 refrigeration
 accessories
 replacement parts
Paints, varnishes, thinners*
Plastics
 compression molded
 extrusions (flexible, rigid,
 dual durometer)
 injection molded
 molding and extrusion
 resins
 transfer molded
 vacuum formed
Progressive dies
Punch presses
Reclaiming ovens*
Relays
 electrical
 electronic
Rotors*
Rubbers, Heat Resistant
Screw machine products
Signs
 indoor-outdoor
 point-of-purchase
 illuminated
 metal
 plastic
Sleevings
 coated
 plain
 treated
 woven
Solenoids
Starter armature end fibers
Stator winding equipment
Switches
 electrical
 manual
 reed
 thermal
Systems control packages
Tapes
 woven
 slit
 pressure sensitive
Taping machines
Terminal blocks
Terminal presses
Terminals
 bullet
 electrical
 electronic
 headlight
 magnet wire piercing
 pin
 ring
 screw
 snap-on
 spade
 spark plug
 tab
Thermostats
 disc
 strip
 hydraulic actuated
Transformers
 electrical

*Denotes products distributed but not manufactured by Essex.

Basic Products List (continued)

electronic	ignition
TV/radio replcement	inside-outside station
Tubing	interlocked armored
extruded	lead-in, TV, FM
flexible	lead sheathed
heat shrinkable	line
rigid	locomotive
spiral wrapped	low voltage control
supported	machine tool
unsupported	magnet
Twines*	magnetic recording
treated	medical
untreated	mil. spec.
plain	miniature
coated	mobile home
Valves	motor lead
gas	neoprene insulated
electro-magnetic actuated	neoprene jacketed
bi-metal actuated	non-metallic sheathed
plumbing	nylon jacketed
Wire and cable	orthodontic
aerial	parallel
air frame	plated, nickel or silver
airport	polyethylene insulated
aluminum	polyethylene jacketed
aluminum alloy	portable power
aluminum covered steel	precision alloy
annunciator	primary
antenna	rubber insulated
appliance	rubber jacketed
audio	self supporting
automotive	service entrance
bare	shielded
bare armored ground	signal
battery	silicone rubber insulated
blanket	stainless alloy
bridle	stainless steel
building	starter armature formed
burial	station
butyl insulated	steel shielded
CATV	stranded
coaxial	street lighting
communications	submersible pump
construction	suture
control	teflon insulated
copper	telephone
copper alloy	telemetering
cotton covered	thermoplastic insulated
cross-linked polyethylene	thermoplastic jacketed
drawn brazed strand	thermostat
drop	trailer
electronic	ultra fine
filled	utility
fixture	weatherproof
gasoline and oil resistant	weaving
high temperature	welding
high voltage	Wire assemblies
hook-up	Wire drawing dies
hypalon insulated	Wire drawing equipment
hypalon jacketed	Wire spools, plastic

*Denotes products distributed but not manufactured by Essex.

Sales Offices & Warehouses



ARIZONA

Phoenix, 3882 W. Osborn Road, 85017 (s5—w5)

CALIFORNIA

Anaheim, 1075 N. Patt Street, 92801 (s4, 6, 8, 9—w1, 6, 8, 9, 11)

Corona, 14292 E. 6th Street, 91720 (s2)

Los Angeles, 777 S. Mission Road, 90023 (s5, 7—w2, 4, 5, 7)

Richmond, 100 W. Ohio Avenue, 94804 (s8, 9—w1, 8, 9)

San Francisco, 777 Mariposa, 94107 (s2, 4, 5—w2, 4, 5)

COLORADO

Denver, 4600 Holly, 80207 (s8, 9—w4, 8, 9)

FLORIDA

Tampa, 2701 Adamo Drive, 33605 (s5, 8, 9—w5, 8, 9)

GEORGIA

Atlanta, 3316 Hamilton Blvd., S.W., 30315 (s2, 5—w2, 5)

Atlanta, 170 Ottley Drive, 30324 (s8, 9—w4, 6, 8, 9)

Atlanta, 1806 Plymouth Road, N.W., 30325 (s5—w5)

ILLINOIS

Chicago, 3501 W. Addison, 60618 (s2, 4, 6—w2)

Chicago, 4545 Cortland, 60638 (s5)

Chicago, 950 W. 40th Street, 60609 (s8, 9—w8, 9)

Chicago, 4545 Armitage, 60639 (s7—w7)

Chicago, 6235 S. Harlem Avenue, 60638 (s4)

Chicago (Niles), 7550 Oak Park Avenue, 60648 (s5—w5)

Decatur, 800 E. Garfield Avenue, 62526 (s1—w1)

Rockford, 2816 N. Main Street, 61101 (w6)

INDIANA

Andrews, 303 N. Jackson Street, 46702 (s7)

Auburn, West Township Road, 46706 (s2)

Columbia City, U. S. Highway 30 West, 46725 (s8, 9—w5, 7, 8, 9)

Fort Wayne, P. O. Box 958, Meyer Road, 46801 (s13)

Fort Wayne, 1508 Wall Street, 46804 (s9)

Fort Wayne, 1510 Wall Street, 46804 (s5)

Fort Wayne, 1601 Wall Street, 46804 (s6—w6)

Fort Wayne, 2817 Goshen Rd., 46808 (w7)

Fort Wayne, 3405 Engle Road, 46809 (s14)

Jeffersonville, 835 Spring St., 47130 (s7—w7)

Kendallville, W. Mitchell Street, 46755 (w6)

Logansport, 131 Godfrey Street, 46947 (s2)

Marion, 2601 S. Adams Street, 46953 (s8—w8, 9)

Mitchell, Grissom Avenue, 47446 (s2—w2)

Muncie, P.O. Box 2423, 47302 (s3—w3)

Peru, 600 W. 7th Street, 46970 (s3—w3)

Union City, 409 W. Oak Street, 47390 (s7—w7)

Vincennes, Box 266, 47591 (w6)

KANSAS

Pauline, University Blvd. & East Street, 66525

(s8, 9—w4, 8, 9, 11)

CODE KEY

w Warehouse	8. Power Conductor Div.
s Sales office	9. Wire & Cable Div.
1. Communications & CATV Div.	10. Wire Assembly Div.
2. Controls Div.	11. Essex/Casco
3. Electro-Mechanical Div.	12. Essex/NPI (Neon Products, Inc.)
4. Industrial Wire Products Div.	13. Transport Motor Express, Inc. (TMX)
5. IW1 Div.	14. Essex Custom Machinery (Ft. Wayne Tool & Die)
6. Magnet Wire Div.	
7. Metal & Plastic Products Div.	

Sales Offices & Warehouses (continued)

KENTUCKY

Louisville, 615 Louisville Trust Bldg. 40202 (s12)
Paducah, P. O. Box 1350, Carneal Road, 42001 (w8, 9)

MARYLAND

Baltimore, 2610 Georgetown Road, 21230 (s5—w5)

MASSACHUSETTS

Boston, 11 Stilling, 02210 (s8, 9—w8, 9)
Peabody, 247 Lynnfield Street, 01960 (s5—w5)

MICHIGAN

Berrien Springs, 100 Tudor Road, 49103 (s2, 4)
Coldwater, 301 Industrial Ave., 49036 (w7)
Detroit, 6233 Concord Avenue, 48211
(s3, 5, 7, 8, 9, 10—w3, 5, 7, 8, 9, 10, 11)
Grosse Pointe, 10 Nottingham Building, 15324 E. Jefferson
Ave., 48230 (s7)
Hillsdale, 170 E. South Street, 49242 (w6)
Three Rivers, 4th Street, 49093 (s8, 9—w8, 9)
Troy, 1955 Stephenson Highway, 48084 (s7—w7)

MINNESOTA

Minneapolis, 3230 E. Hennepin, 55413 (s2, 8, 9—w8, 9)

MISSOURI

Kansas City, 1229 Atlantic, 64116 (s5—w5)
St. Louis, 4343 Duncan Avenue, 63110 (s2, 5—w5)
St. Louis, 5959 St. Louis Avenue, 63120 (s6, 8, 9—w8, 9)
St. Louis, 4200 Miami Street, 63116 (s2)

NEW JERSEY

Linden, 401 E. Linden Ave., 07036 (s8, 9—w8, 9)

NEW YORK

Arcade, 108 Park Street, 14009 (w7)
DeWitt, 4623 E. Genesee, 13214 (s2)
Maspeth, 56-23 55th Avenue, 11378 (s8, 9—w8, 9)
New York, 104 W. 40th Street, 10018 (s11)
New York, Sperry Rand Building, 1290 Avenue of Americas,
10019 (s12)
Pittsford, #1 Grove Street, 14539 (s8, 9—w8, 9)
Rochester, 45 Saginaw Drive, 14623 (s8, 9—w8, 9)
Syracuse, 202 Arterial Road, 13206 (s5)

NORTH CAROLINA

Charlotte, 1101 N. Hoskins Road, 28208 (s5, 8, 9—w5, 8, 9)
Morgantown, P. O. Box 417, 28655 (w7)
Mt. Airy, P. O. Box 807, 27030 (s7, 9—w7)

OHIO

Cincinnati, 10591 Chester Road, 45215 (s5—w5)
Cleveland, 1231 E. 26th Street, 44114 (s5—w5)
Cleveland, 4500 Willow Parkway, 44125 (s2, 6, 8, 9—w8, 9)
Dayton, 2077 Embury Park Road, 45414 (s2, 6, 7)
Lancaster, 211 N. Columbus Street, 43130 (s14)
Lima, Neon Avenue, 45802 (s12)
Mansfield, P.O. Box 1007, 44903 (s2)

OKLAHOMA

Oklahoma City, 420 N. Pennsylvania, 73107 (s5—w4, 5)

OREGON

Portland, 1900 N.E. 181st Avenue, 97230
(s5, 8, 9—w1, 5, 8, 9)



PENNSYLVANIA

Conshohocken, Railroad & End Streets, 19428
(s2, 8, 9—w4, 8, 9)
McKees Rocks, Graham Street Extension, 15136
(s6, 8, 9—w8, 9)
Philadelphia, 915 N. Broad Street, 19123 (s5, 7—w5)

PUERTO RICO

Carolina, P. O. Box 1943, La Ceramica Annex, 00630
(s5—w5)

SOUTH CAROLINA

Belton, P. O. Box 547, 29627 (s11—w11)
Bennettsville, Highway 79, 29512 (s6—w4, 6)
Chester, P. O. Box 68, 29706 (w1)

TENNESSEE

Franklin, Columbia Highway, P. O. Box 625, 37064 (s2)
Hixson, 5228 Hixson Pike, 37343 (S2)
Memphis, 2172 Wharf St., 38113 (s6, 8, 9—w8, 9)
Nashville, 6526 Rolling Fork Drive, 37205 (s2)

TEXAS

Dallas, 4924 Greenville Avenue, 75206 (s2)
Dallas, 3777 High Vista, 75234 (s12)
Dallas, 2801 Pierce Street, 75233 (s5, 8, 9—w2, 5, 8, 9)
Houston, 2222 Leeland Avenue, 77003 (s5—w5)
Houston, 5990 1/2 Griggs Road, 77023 (s8, 9—w8, 9)
Houston, 12806 Butterfly Lane, 77024 (s8, 9)

WASHINGTON

Seattle, 5501 First Avenue, South, 98108 (s5—w5)

WISCONSIN

Milwaukee, 2040 W. Wisconsin Avenue, 53233 (s5)
Milwaukee, 2825 N. Mayfair Road, 53222 (s6)

FOREIGN

CANADA

Renfrew, Ontario, 20 Arthur Avenue, E., P. O. Box 185 (s2)

ENGLAND

Solihull, Warwickshire, Northampton House, Poplar Road (s2)

GERMANY

2 Hamburg 61, Postfach 61 02 41 (s2)

NORTHERN IRELAND

Londonderry, Bligh's Lane (s10)

SWEDEN

Box 156, Vastra Frolunda 1 (s2)

CODE KEY

- w Warehouse
s Sales office
1. Communications & CATV Div.
2. Controls Div.
3. Electro-Mechanical Div.
4. Industrial Wire Products Div.
5. IWI Div.
6. Magnet Wire Div.
7. Metal & Plastic Products Div.
8. Power Conductor Div.
9. Wire & Cable Div.
10. Wire Assembly Div.
11. Essex/Casco
12. Essex/NPI (Neon Products, Inc.)
13. Transport Motor Express, Inc. (TMX)
14. Essex Custom Machinery (Ft. Wayne Tool & Die)