



English version



Jacques Jumeau

Technology of components used in heating.

Chapter 18

Introduction to humidistats technology



Introduction to nylon ribbon humidistats technology

(other names : Humidostats, hygrostats, humidity switches)

A/ Operation principle

Ultimheat humidistats are constructed according to the hygroscopic nylon film technology.

Nylon is a particularly hygroscopic material, which has the property of expanding in the presence of moisture.

Nylon ribbons humidistats use this property by measuring the elongation of a strip of nylon as a function of relative humidity. This extension is then transmitted through a lever system to an electrical contact.

A set point adjustment shaft allows to change the actuator lever position and thus set the threshold that will trigger the humidistat

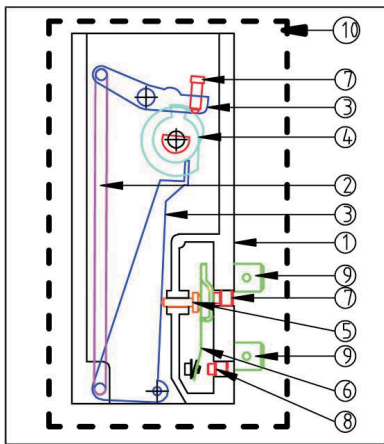

Schematic diagram

A humidistat is composed of 10 main components:

- 1: Frame
- 2: Hygroscopic ribbon
- 3: Lever mechanism
- 4: Adjustment shaft
- 5: Plunger
- 6: Micro-switch
- 7: Calibration screw
- 8: Differential adjustment screw
- 9: Electrical terminals
- 10: Wall mounting box (optional)

B: Main components description

1: The frame

It maintains mechanical parts together. Humidistat is inherently used in wet and humid area, and plastic body is preferable to metal to avoid the risk of corrosion. It also provides better electrical insulation, which is particularly important for applications in humid conditions.

It allows to mount the switch with two screws, and mounting design allows adjustment shaft to be located in front or lateral position. Frame is widely open around the nylon film to allow good air circulation.

2: The hygroscopic ribbon

The relative humidity of the air is the percentage of water vapor contained in the air before compared to the amount where it condenses. If this rate reaches 100%, the water vapor condenses into liquid water. The amount of water vapor that the air can contain increases with the temperature of the air. The term relative humidity is thus well suited, since a relative humidity at a given ambient temperature will not correspond to the same number of grams of water per cubic meter of air at a different temperature

Grams of water by cubic meter of air related to relative humidity and air temperature

°C	20%	40%	80%	100%
10	2	3.8	7.5	9.4
20	3.5	7	13.8	17.4
30	6	17.1	24.3	30.5
35	7	14	29	38

It is made of nylon because of its two specific hygroscopic characteristics.

- The rate of elongation according to the change of relative humidity. This rate is

Introduction to humidistats technology

about 0.2% at 50% relative humidity and is the largest of all plastics. This is the same magnitude order than human hair, which were once used to measure the relative humidity.

- The permeability of the nylon to water vapor, and specially the speed at which it exchanges water vapor with the environment. This parameter is characterized by testing according to ASTM (measure of “moisture vapor transmission rate, MVTR” also known as “water vapor transmission rate,” WVTR).

The water molecules in the air have a diameter of about 0.05 microns. They produce polar bonds with amide groups of the molecules of nylon and inserts themselves between them, causing the expansion of these molecules. Some varieties of nylon can absorb up to 2.7% by weight of water at 50% relative humidity and up to 9.5% at saturation (at room temperature). The result is an elongation of the molecular matrix of nylon. This process is completely reversible. According to the method of manufacture of nylon film and its subsequent treatment, the water vapor molecules will penetrate more or less quickly in the film, and the reaction time of the latter to changes in relative humidity in the air will be modified.

The reaction time of the nylon film to reduced relative humidity becomes excessively long for values below 20%. This is why hygrostats settings begin at this value.

The selection of the ribbon raw material film is essential. Obviously, then, the exchange surface of the film must be optimized, and in particular its thickness must be as small as possible, while maintaining the tensile strength mechanical properties needed to actuate the micro-switch.

This is the difficult optimization of all these parameters that provides an efficient humidistat, without drift in time.

3: The 2 levers transmission mechanism.

These two levers will maintain the nylon ribbon and transmit its elongation to the electrical contact device. Their relative position is determined by the adjustment shaft.

4 : Adjustment shaft

This adjustment shaft can be located on the front or on the side of the humidistat. It comprises a cam which ensures the movement of the levers above depending on the relative humidity to achieve. It also includes stops that will ensure the mechanical locking of the contact (open or closed depending on the position) at minimum and maximum angulation.

This is the shape of the cam which provides the humidity setting range. It is therefore possible to make specific setting ranges, but it requires to make a specific plastic injection mold for each range. The adjustment shaft length, size and position of its flat can be made on request with the same constraints.

5: Plunger

This plunger provides the interface between the levers holding the nylon ribbon and the electrical part of the micro-switch. It transmits the movement to snap action contact blade.

6: The micro-switch (For more information on the electrical contacts, see the technical introduction of the “Thermostats for incorporation” .

The force developed by the nylon film for actuating the electrical contact device is very small (a few grams). Applications of this product (humidifiers and dehumidifiers) require relatively high breaking capacity in 230/240V, so it is necessary to use a snap-action mechanism for this. Therefore, the electrical contact mechanism is a critical point in the humidistat.

The nature of the contacts, their shapes must be optimized to reach the rating requested by the application.

In addition, these humidistats are used in critical environmental conditions, close to the dew point, which means that condensation may occur.

For this reason, humidistats should not be used on voltages higher than 24V in conditions specifications above 90% relative humidity. We also recommend the use of gold-plated silver contacts to prevent the contacts oxidation, at least during the

storage period before use, if storage relative humidity is high

7: Calibration screw

Hygrostats are calibrated with this screw under conditions of constant temperature and humidity (42% relative humidity and 23°C). This screw, which is not intended by a user setting, sets the correct adjusting shaft position at the humidity calibration value.

8: Differential adjustment screw

The humidistat differential is the relative humidity difference between the value at which the contact will open and at which it will close. This is a factory parameter set with this screw. This screw is sealed, without user access and must not be tampered.

The value of the humidistat differential is given at the calibration point (see above calibration). Because of the mechanical properties of the nylon film, the differential value is not the same over the entire adjustment range, and increases with the relative humidity value.

Two factory set values are possible: 5% (+ / 3) or 15% (+ / -5).

9: Electrical connection

Electrical connection for humidistat for incorporation are made by two or 3 tabs 6.3 x 0.8 mm. On models with protection housings, or on demand of incorporation devices, they are equipped with screw terminals.

10: The protection housing (optional)

- Humidistats for incorporation (without protection housing) are rated IP00 and are intended for integration by professional customers, usually the OEM of the machine or equipment in which it is used. So this is the machine or equipment must provide protection against water, dust, shock and other contaminants.

- Wall mounting humidistats and Din Rail mounting humidistats for electrical cabinets.

The protection housing of these devices is intended for in-door application. To ensure proper control of the relative humidity, it should be placed appropriately in an area where the air circulates naturally.

Given the needs of air circulation around the measuring element, it provides limited protection against penetrating objects (IP20) and shock (IK02). These devices must be installed by a qualified electrician and in accordance with electrical regulations and safety standards.

- Protection against explosive atmospheres, gas and dust: these humidistats are not designed for use in these environments and do not meet the standards in this application

C: Use and installation of humidistats

C-1 Absolute humidity, relative humidity and dew point.

The amount of water that may contain air, vapor invisible, is limited and linked to the temperature.

Beyond a given limit, one sees fog and condensation. This is the dew point (or saturation value).

The saturation value in g/m³ is the maximum quantity of water that air may contain in the form of invisible vapor, before the appearance of fog or condensation. This saturation value is a function of temperature. For more information about these values, see the Mollier diagram. Absolute humidity is represented by the number of grams of water per cubic meter of air.

But the feeling of moisture and visible phenomena related to moisture are not only due to the amount of water contained in the air

example:

- Air with a 6 g/m³ absolute humidity and a temperature of 5°C seems humid, fog is present, a sheet of paper tends to soften, the laundry does not dry, the salt in the kitchen gets wet.

Introduction to humidistats technology

- Air having the same absolute humidity of $6\text{g}/\text{m}^3$ but at a temperature of 30°C . feels dry, it is clear, the paper is rigid, laundry dries quickly, the salt is dry. The absolute humidity (defined by the weight of water per M^3 of air) is not sufficient to describe the concept of humidity, it is necessary to take into account the ambient temperature. The relative humidity (RH) is the combination of these two factors. Hygrostats provide control depending on the relative humidity

C-2 Humidistats applications

The main uses of humidistat are:

- Limit or avoid condensation in rooms or enclosures
- Maintain a humidity level in a zone called “comfort zone,” neither too dry nor too wet. The comfort zone is generally defined as being between 20 and 25°C and 40 to 60% relative humidity.
- Avoid desiccation of products sensitive to low humidity, such as wood (furniture, barrels) bottles corks in wine cellars.

C-3 Impact of the outdoor temperature and its dew point

When the temperature outdoor is less than -1°C , the windows and improperly insulated walls temperature can reach the dew point, and this will cause the formation of condensation on the windows (vapor) and walls.

The diagram below provides guidance on the setting of maximum humidity depending on the outdoor temperature.

If condensation appears at suggested set points, then lower the setting by successive steps of 5% . After each setting, wait 6 hours to achieve stabilization before changing the setting.

Outdoor temperature	-20	-10	-5	0	+20
Set point adjustment	25 %	30 %	35 %	40 %	50/55%

C-4 Dehumidification

Dehumidification control can be used to keep the relative humidity constant during unoccupied periods, whatever the ambient temperature, to maintain the humidity in the comfort zone if this rate is too high due to external climatic conditions (Humid tropical islands and zones nearby sea or lakes) or in areas of the home where high humidity may occur because of the activity that is performed or equipment installed therein (kitchen, bathroom, laundry room, gym, swimming pool). This method maintains the relative humidity constant avoiding high moisture levels associated with the formation of mold.

In this system the humidistat controls a dehumidifier, or a ventilation system (if the outdoor humidity is lower than the relative humidity of the house area)

C-5 Humidification

In winter, when the air is too dry, and / or when the heating system or air conditioning dries the air, the humidistat will allow, by starting a humidification system, the rise the relative humidity, thus providing comfort to the breath. This also prevents the furniture and wood to cracks because they shrink. Used in a wine cellar, it prevents corks and wood barrels to shrink.